

# Pro/REPORT Bill of Material Manipulation:



## Table of Contents:

- 1) [Objective](#)
- 2) [Overview](#)
- 3) [Tutorial](#)

## Objective:

At the end of this tutorial, you will be able to:

- Substitute automatic report quantities with user defined quantities
- Condense multiple part versions to one line on a Bill of Material report

## Overview:

Use of Pro/REPORT to automatically create Parts Lists on drawings with associated Balloons is a simple quick task in Pro/ENGINEER. There are two instances that challenge beginning users:

- You have two versions of a part with different names in the same assembly. A spring in two different states of compression or a hinge open and closed are typical examples. Rather than list these items multiple times, you want them on a single line of the Pro/REPORT table with the total quantity. You want this to happen automatically.
- You would like to show some items with a quantity and some with a string, like A/R (As Required).

This tutorial assumes that you already know how to create associative BOM tables using Pro/REPORT. For more information see the knowledge base or “Pro/DETAIL tm Topics Collection” guide.

## Tutorial:

First we will examine the case of a spring shown in two different states of compression. In the following assembly the same spring is used twice, but in one instance it is compressed. This requires the two springs to be different Pro/ENGINEER files. In this case the compressed state is a family table instance of the free state. The free state is named “100-600.prt” and the compressed state is 100-600\_COMP.prt.” Look at the part name column in the assembly model tree. Notice that both parts have the same part name parameter. The drawing BOM repeat region will reference this “*part\_name*” parameter not the model name. The 100-600 item on the drawing will show a quantity of two.

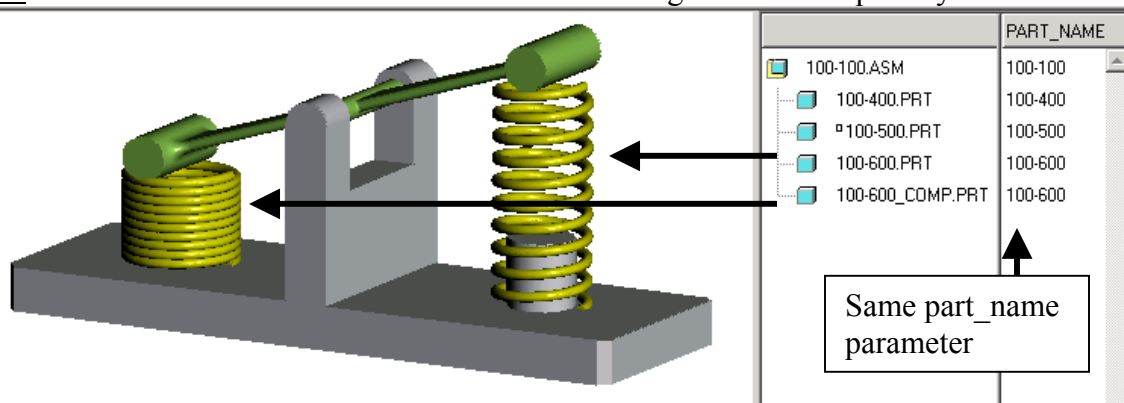

Now, you do not want to have to enter the part number for both the file name and the *part\_name* parameter. This could result in typographical errors. The following relation

will set the part\_name parameter to be equal to the file name so that you only enter the number once:

Part\_name = rel\_model\_name

If this relation is added to a template part or assembly no user will ever need to create it.

Now at this fictional company, the part numbers have three characters a dash and three more characters. I also appended “\_comp” to identify the compressed spring. In this case I want to only use the first seven characters of the file name 100-600\_COMP. A slight change to the relation is all that is needed:

Part\_name = extract(rel\_model\_name,1,7)

Only the first seven characters will be used.

The drawing with a BOM is shown below.

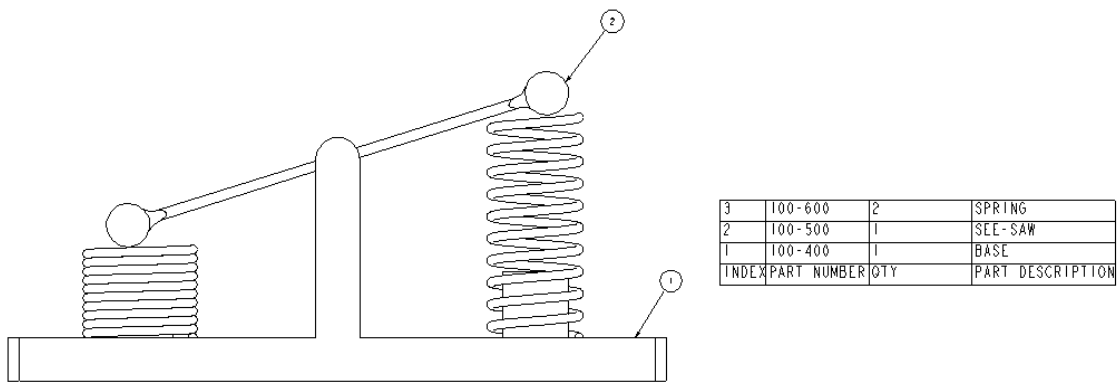

One drawback of this method is that the balloon for the items being condensed into one line cannot be shown automatically. All others in the table can be shown automatically.

Now the second case- We will change a quantity to read A/R.

I have an assembly that produces the following BOM:

10	WING_RIVET	533 
9	007_SKIN_02_04	1
8	007_SKIN_02_03	1
7	007_SKIN_02_02	1
6	007_SKIN_02_00	1
5	007_SKIN_01_04	1
4	007_SKIN_01_03	1
3	007_SKIN_01_02	1
2	007_SKIN_01_01	1
1	007_SKIN_01_00	1
INDEX	PART NAME	QTY

I really want this:

10	WING_RIVET	A/R 
9	007_SKIN_02_04	1
8	007_SKIN_02_03	1
7	007_SKIN_02_02	1
6	007_SKIN_02_00	1
5	007_SKIN_01_04	1
4	007_SKIN_01_03	1
3	007_SKIN_01_02	1
2	007_SKIN_01_01	1
1	007_SKIN_01_00	1
INDEX	PART NAME	QTY

We will accomplish this with report relations. There are three steps:

- Create a string parameter for the repeat region to represent quantity
- Set this string parameter equal to the automatically generated quantity in #Repeat Region #Relations
- Add a conditional statement to change the value for a particular item

To create a new parameter choose #Repeat Region#Relations.

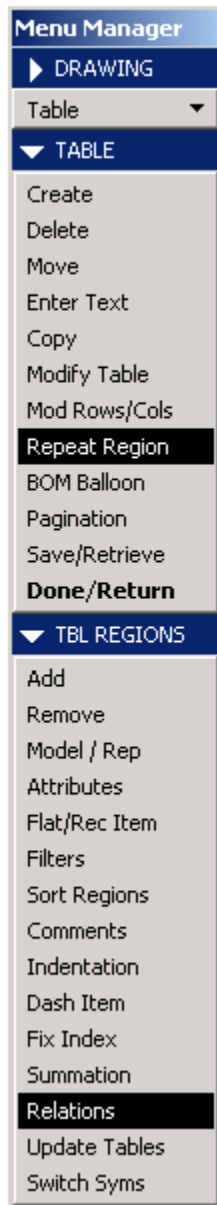

You will be prompted to select a repeat region. After selecting the repeat region in the drawing select #AddParam#String. Give your parameter a name and initial value. I used "new\_qty."

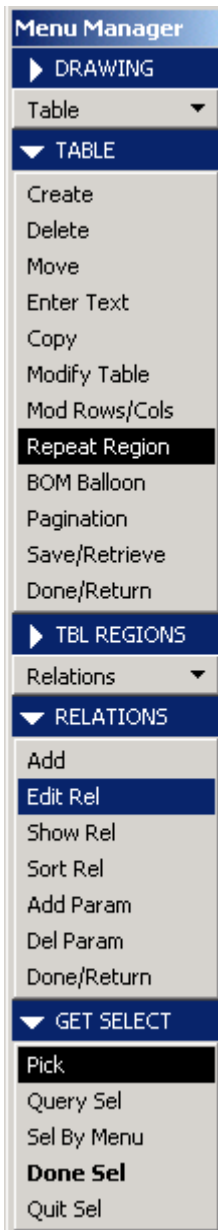

Choose edit relations and type the following in your editor:

```
new_qty = rpt_qty
if asm_mbr_name == "WING_RIVET"
    new_qty = "A/R"
endif
```

Sets new\_qty equal to the automatic quantity for all parts

Changes new\_qty for a particular item

You will of course have different model names. Change your repeat region to use new\_qty.

rpt.index	asm.mbr.name	rpt.rel.new.qty
INDEX	PART NAME	QTY

This change will work even if components are added or subtracted or if the index number changes for the item being tweaked.