

“Capture your Design Intent with Slots”

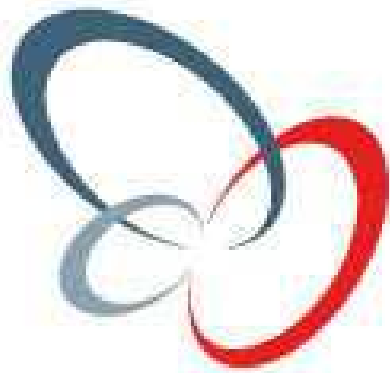

PTC™
Shaping Innovation

Table of Contents:

- 1) [Objective](#)
- 2) [Overview](#)
- 3) [Tutorial](#)
- 4) Test for Retention
- 5) [Tutorial Evaluation](#)

Objective:

At the end of this tutorial, you will be able to:

- Be able to quickly create slots
- Capture your design intent in one feature
- Enable proper assembly techniques based on the center of the slot
- Create an intelligent Axis in the center of slot
- Eliminate the need to create 2 datum planes and then an axis through 2 planes.

Overview:

Quite often we need to create slots in our parts and assemblies. Unfortunately, when these slots are created the design intent is not initially created. This is due to the fact that an axis is not automatically generated off the creation of the slot. More importantly, this axis is not at the center of the slot. When the time comes to assemble hardware to this slot, the correct procedures cannot be used, as there exists only axis on both sides and not in the center. This tutorial will show you a quick way to create the slot and the axis in ONE feature. The key here is that this technique should be used every time a slot is created. As axis are mandatory for capturing your design intent.

Slot Creation Tutorial

1) Create initial cut in part

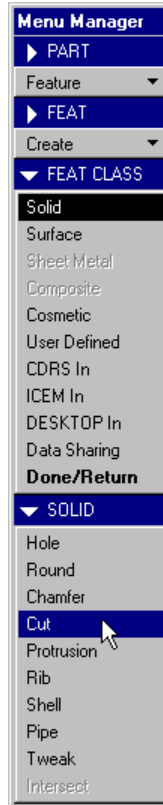
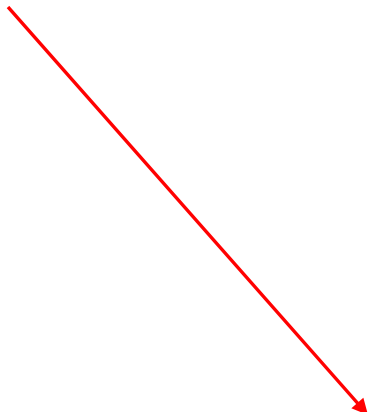

2) Sketch Geometry of Slot:

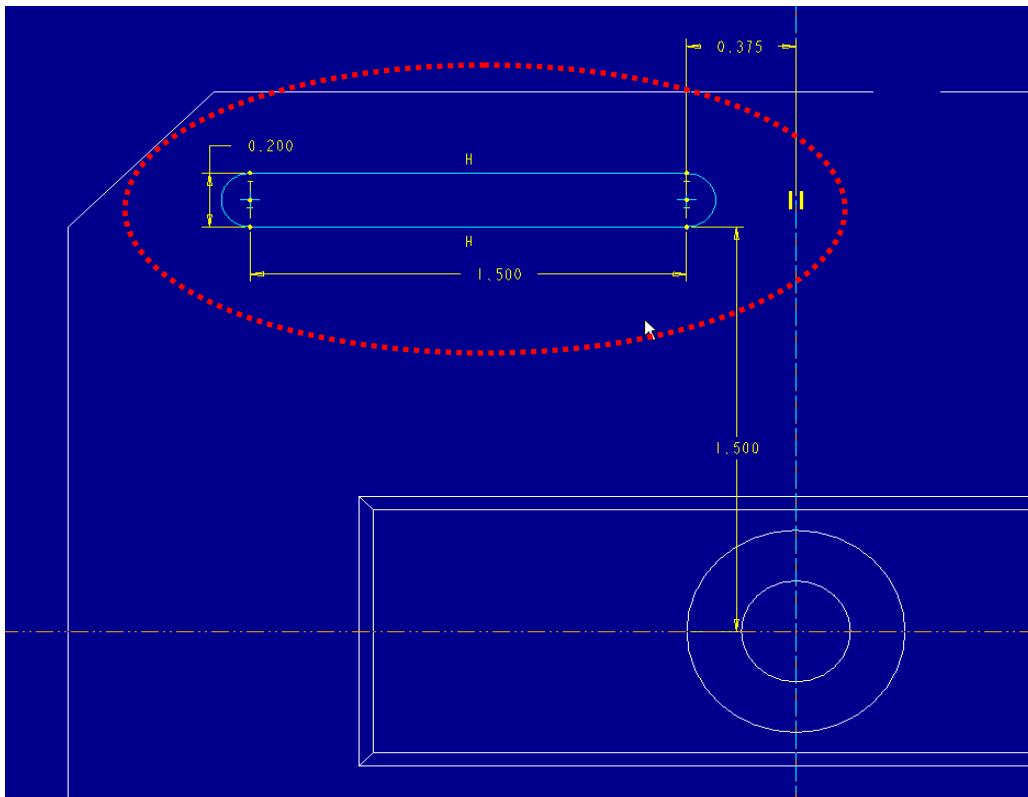

3) Create 1 Line

- a. Ensure that the line snaps to end point of curves.

Notes:

- This will ensure that regardless of how geometry changes, the lines will move accordingly.
- Do not use 2 centerlines, as this will only complicate your sketch and potential cause your sketch to jump around as other geometry is created near this sketch.

Line Creation:

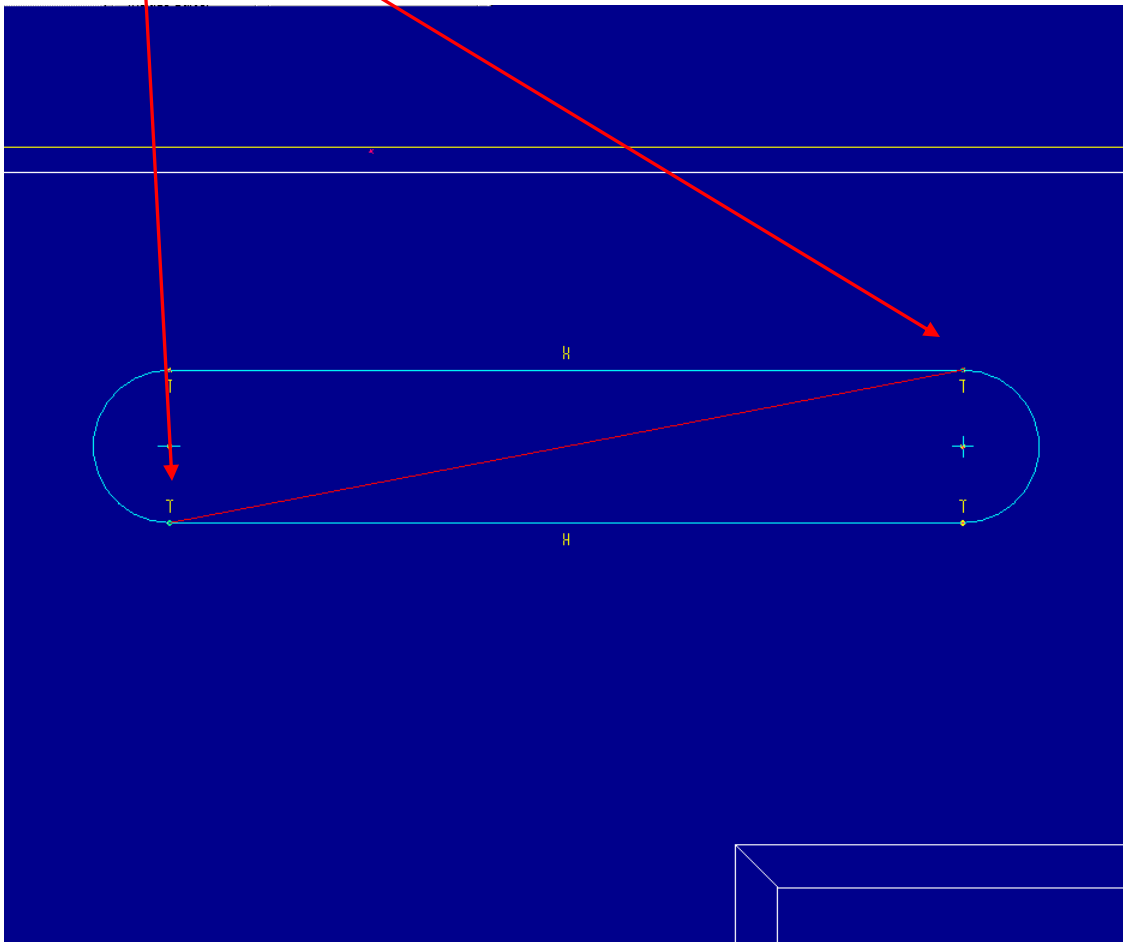

Change to Construction:

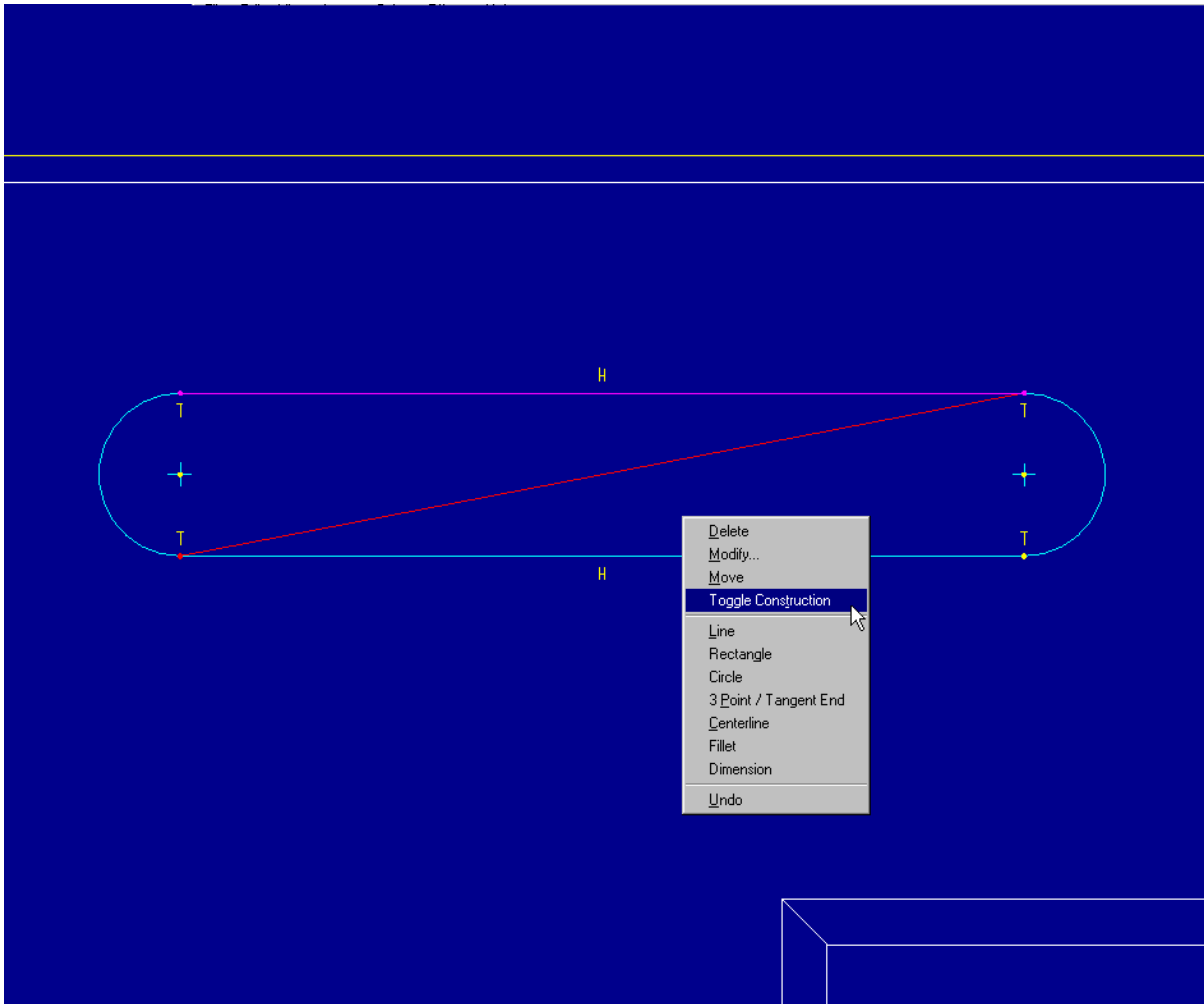

Result:

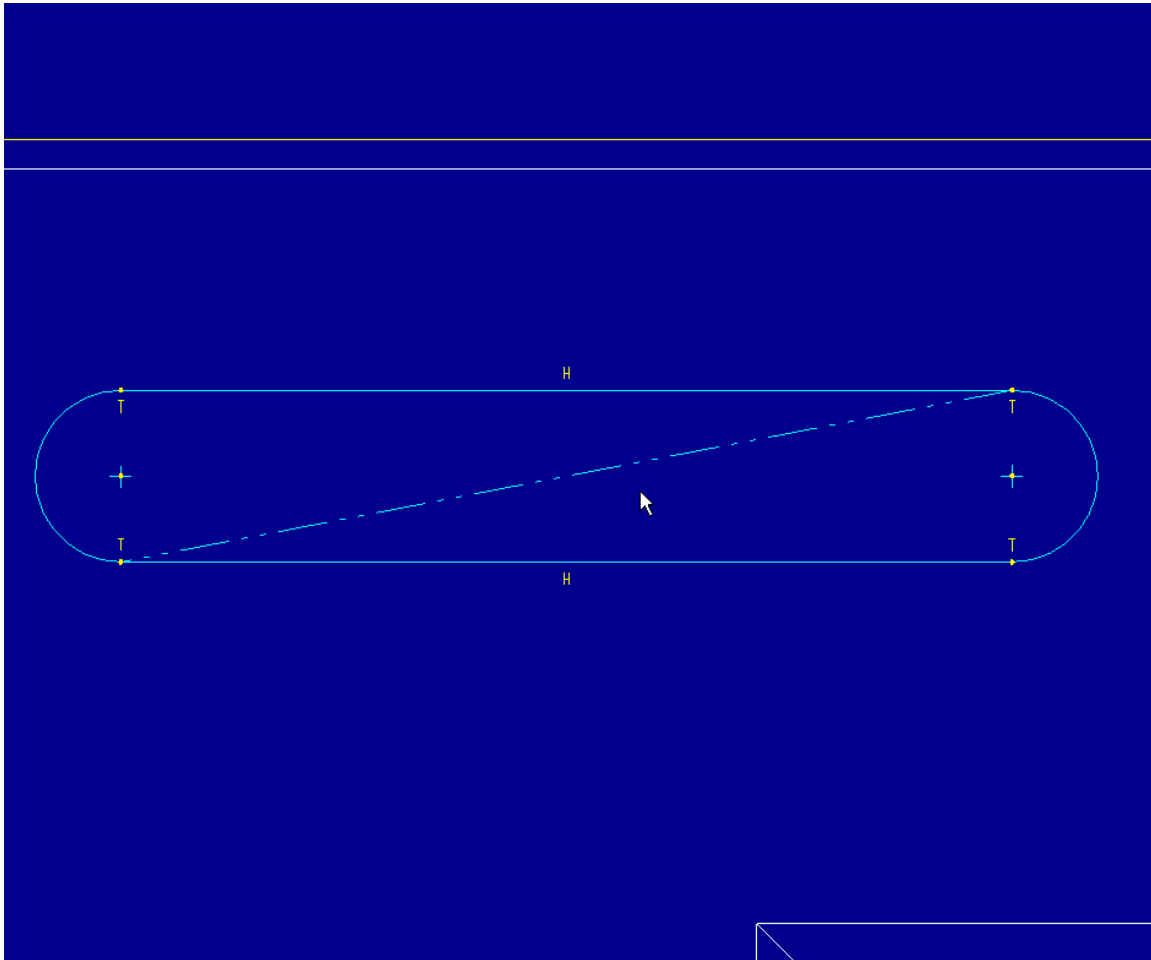

4) Create an **AXIS POINT** from the Sketch Drop down tab:

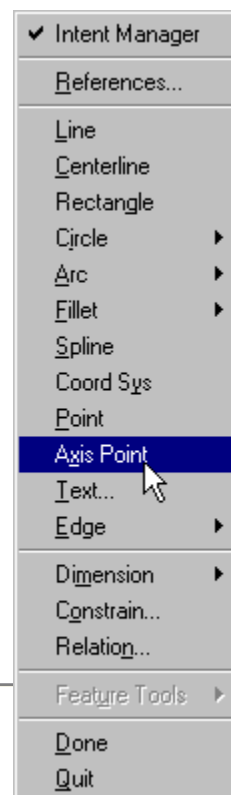
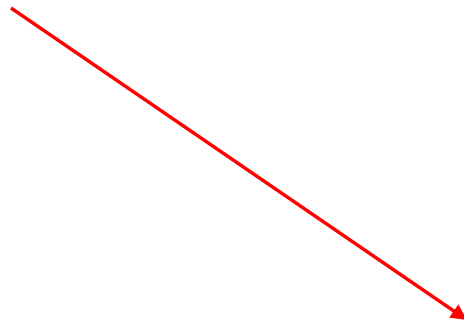

- 5) Place the point at the center of this construction line. As of Pro/E 200i2 sketcher picks up the Mid Point of a line. If using earlier release of Pro/E see end of doc for alternative method.

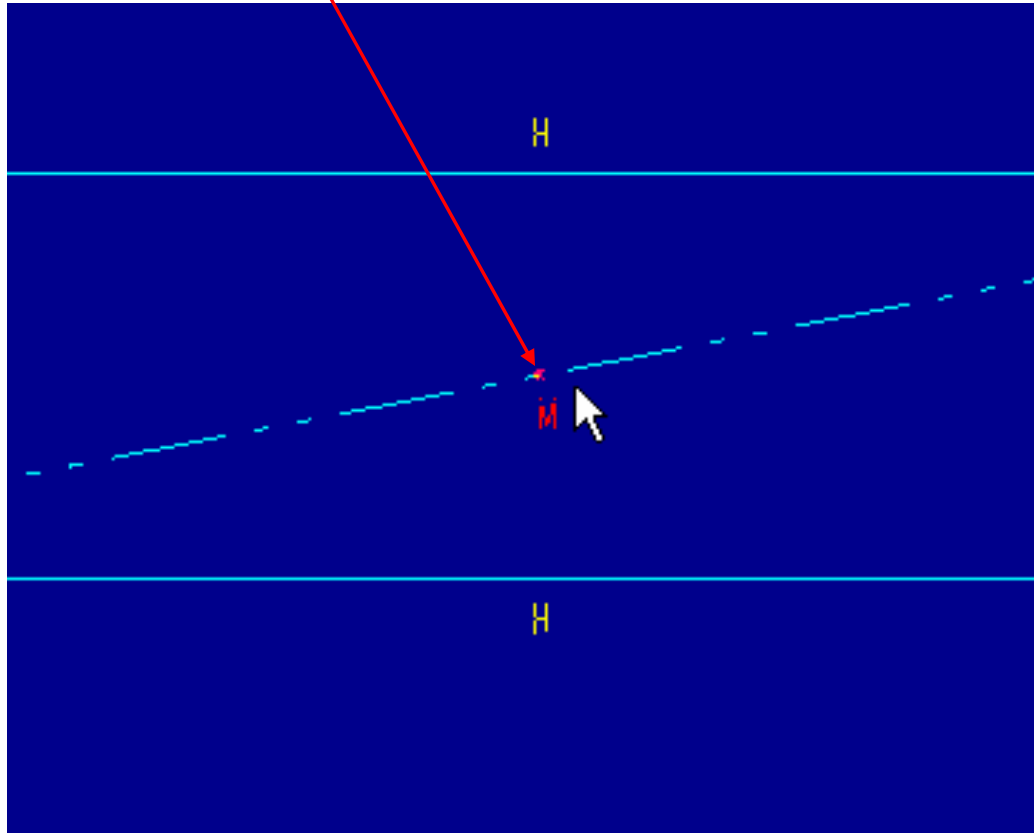

Full View:

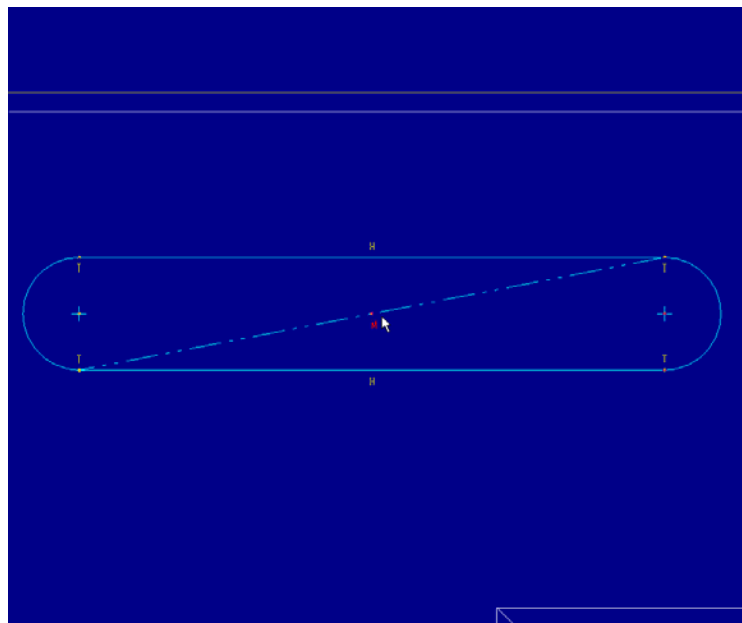

Conclusion:

Now, with one feature, the design intent is captured with an axis created at the center. That axis will always be in the center of the part, regardless of any future changes.

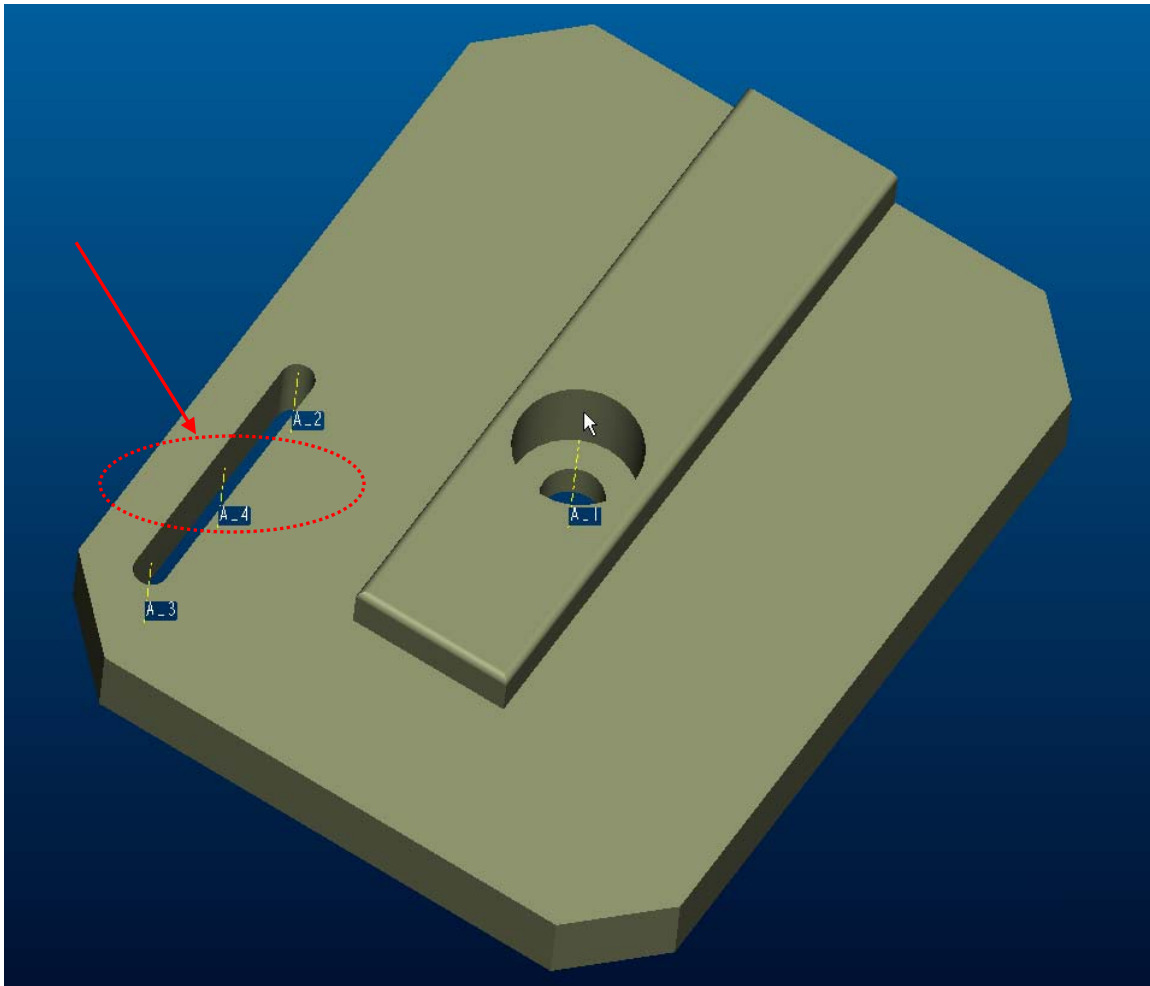

Alternative solution for 2000i or earlier: Create 2 centerlines and place axis point where constructions line cross.

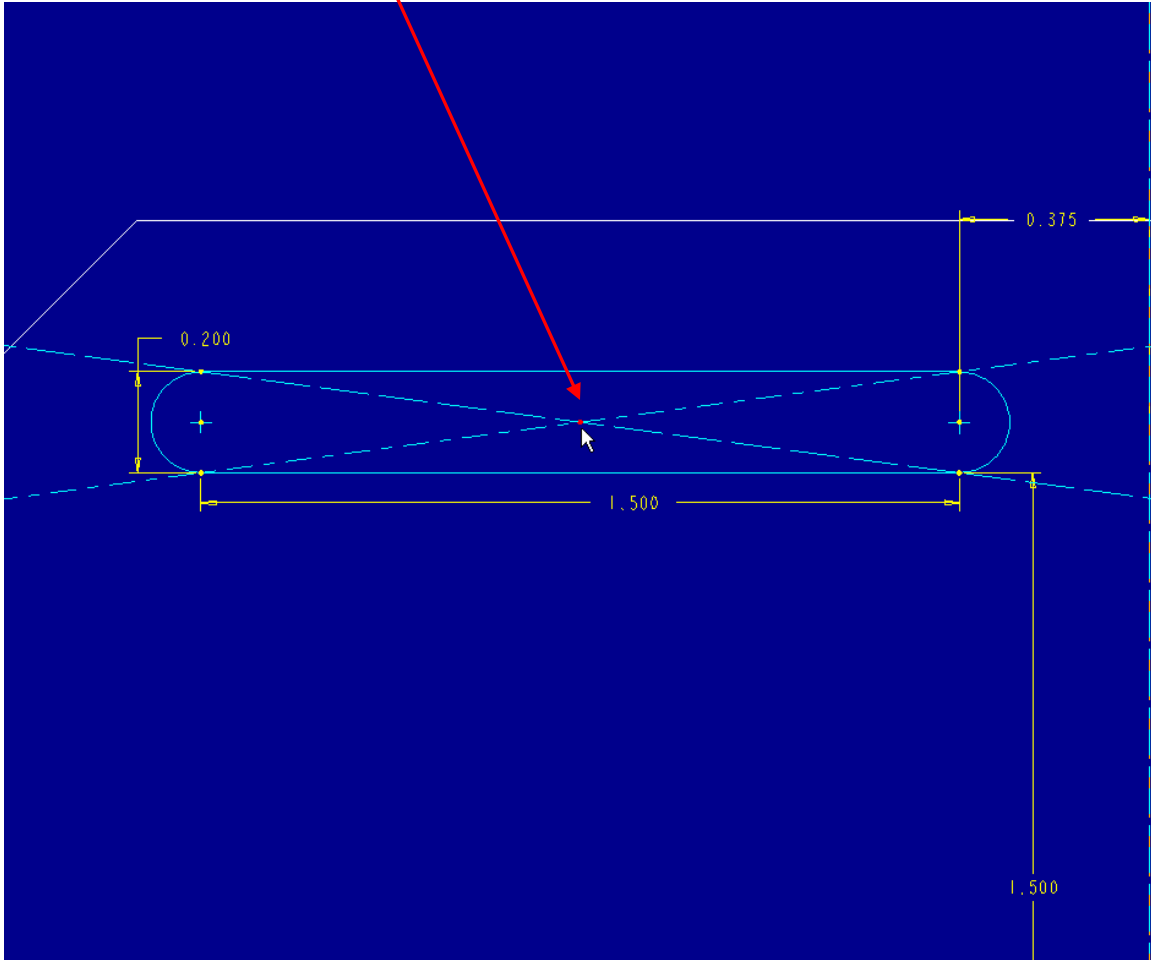

END